

Integrated Magnetics Designs

Challenges

- Space Constraint
- Weight Reduction
- Heat Dissipation

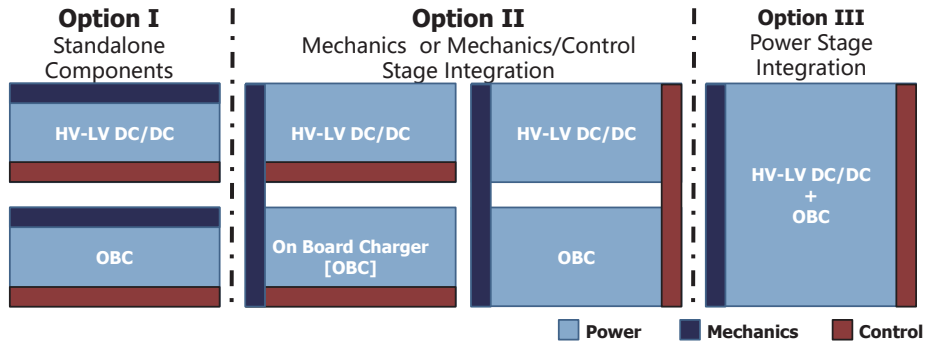

Core Capabilities for High-Power Magnetics

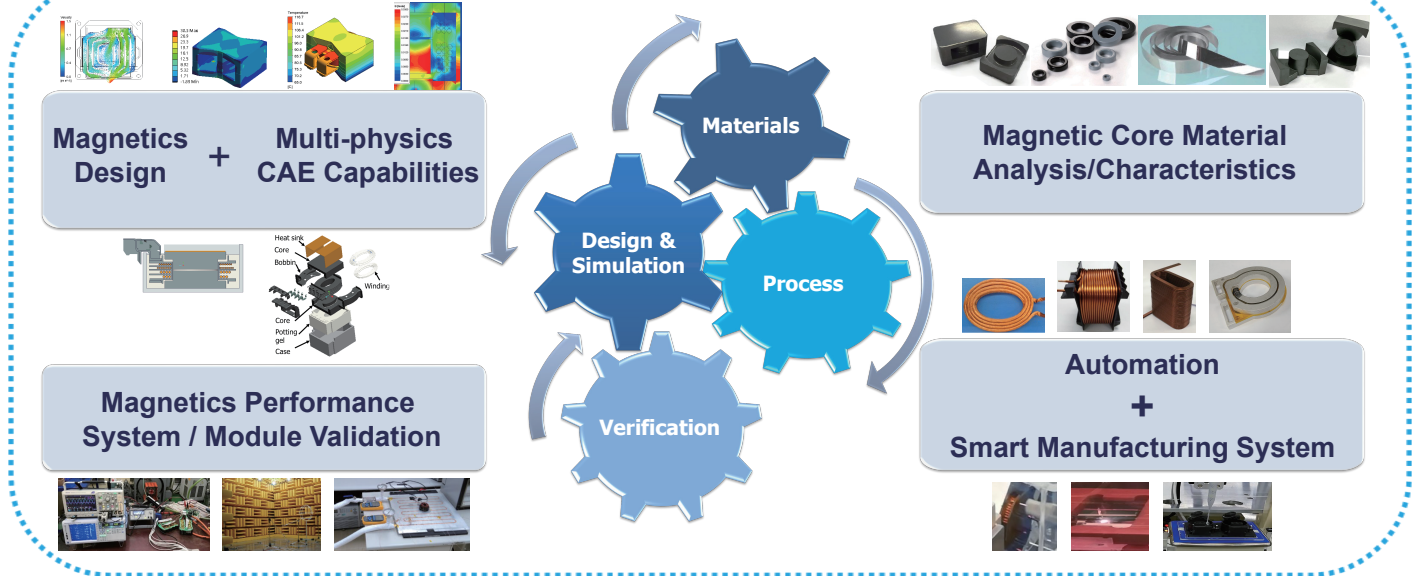

Product Features

Package level integration:

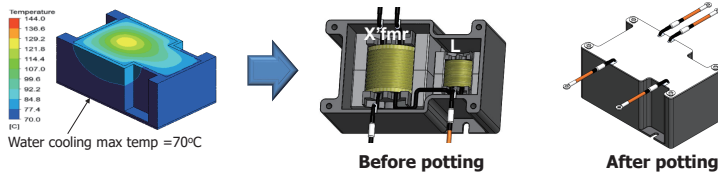

- Features:**
- ✓ Flexibility & customized design
 - ✓ Wide inductance range
 - ✓ Better thermal performance
 - ✓ High-quality potting process

Magnetic integration:

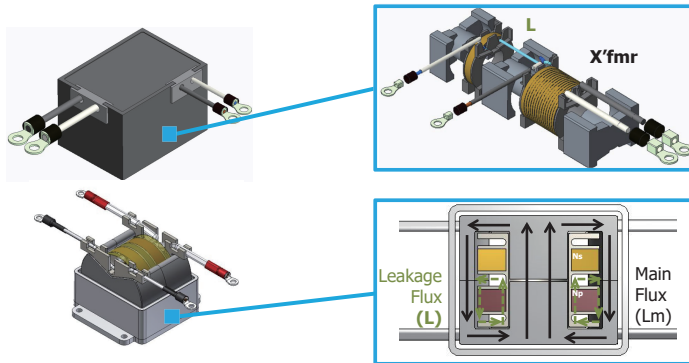

- Features:**
- ✓ Size reduction through core sharing
 - ✓ Leakage as inductor
 - ✓ Compared with discrete design, size (~25% ↓) and weight (~25% ↓)

Function integration:

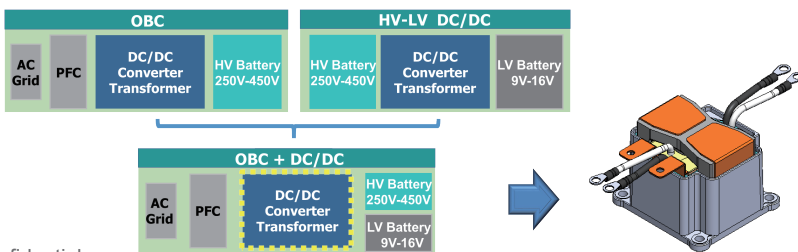

- Features:**
- ✓ Single transformer for HV and LV batteries
 - ✓ Compared with standalone OBC and DC/DC design, size (~35% ↓) and weight (~30% ↓)